

OPERATING GUIDELINES

1. Power up the device by plugging in the power supply.
2. The LED lamp would light up. If the LCD monitor does not automatically turn on. Press the power button of the LCD monitor.
3. Attach the PCB to be inspected to the versatile board holder.
4. Adjust to the desired magnification by twisting the scope.
5. Used the adjustment ladder to find the focus of the desired magnification.
6. To move the adjustment ladder simply turn the ladder adjustment handles (1),(2).
7. The entire camera mount can be moved up and down for different magnification's focus adjustment.
8. To adjust the camera mount. Hold the camera mount firmly then loosen the securing screw (3) of the mount. Move the entire camera mount until proper focus is archived, re-fasten the securing screw (3).

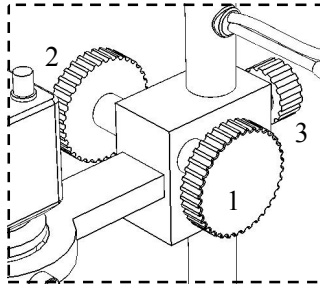

AOYUE[®] INT638

PCB INSPECTION SYSTEM

INSTRUCTION MANUAL

Thank you for purchasing Aoyue 638 PCB inspection system
It is important to read the manual before using the equipment.
Please keep manual in accessible place for future reference.

**ESD
SAFE**

Manufacturer:
AOYUE TONGYI ELECTRONIC EQUIPMENT FACTORY
Jishui Industrial Zone, Nantou, Zhongshan City,
Guangdong Province, P.R.China
<http://www.aoyue.com>

This manual is designed to familiarize and instruct the operator with the proper usage and maintenance of the equipment. Please read carefully and observe the guidelines in order to maximize usage and minimize the risk of injury or accidents .

TABLE OF CONTENTS

Package Inclusion	3
Functions and Features	4
Safety Precautions	4
Assembly	5 — 7
Operating Guidelines	8

ASSEMBLY

-
5. Mount LCD monitor (A) to the LCD monitor holder. (see Fig. 5)
 6. Attach the connecting cable to the base platform receptacle. (see Fig. 5a)
 7. Attach Camera connectors to the CCD camera. (see Fig. 6a)
 8. Plug in the LCD monitor connectors. (see Fig. 6b)
 9. Plug the power supply to the system.

ASSEMBLY

3. Screw the top mount to the base platform assembly. (see Fig. 3)

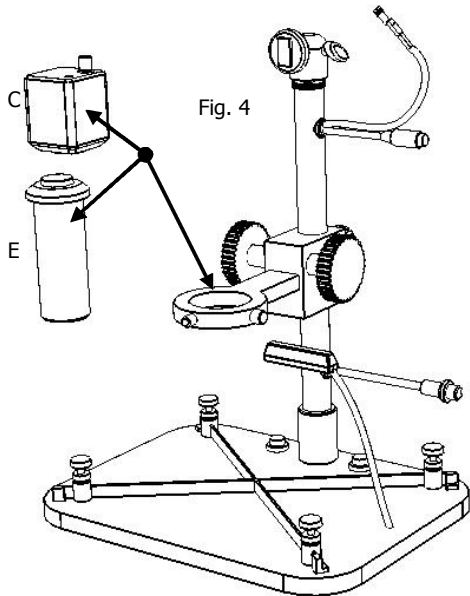
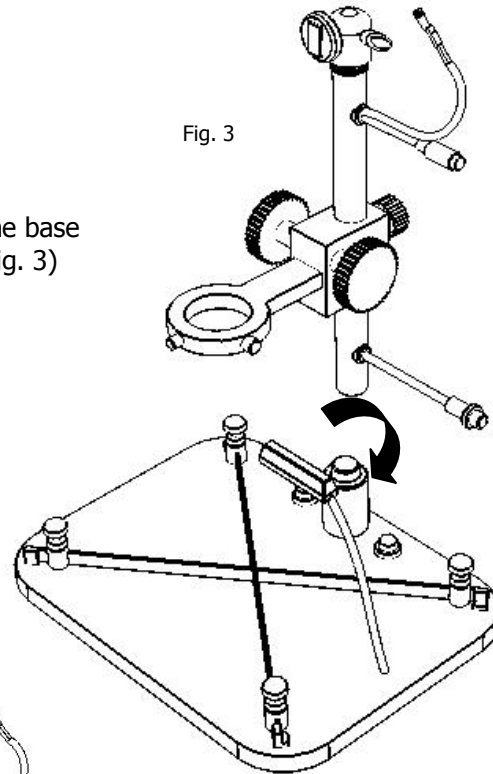

4. Camera Assembly:
 - Screw in the magnifying scope (E) to the CCD camera (C). (see Fig. 4)
5. Slide the camera assembly to the camera holder.

PACKAGE INCLUSIONS

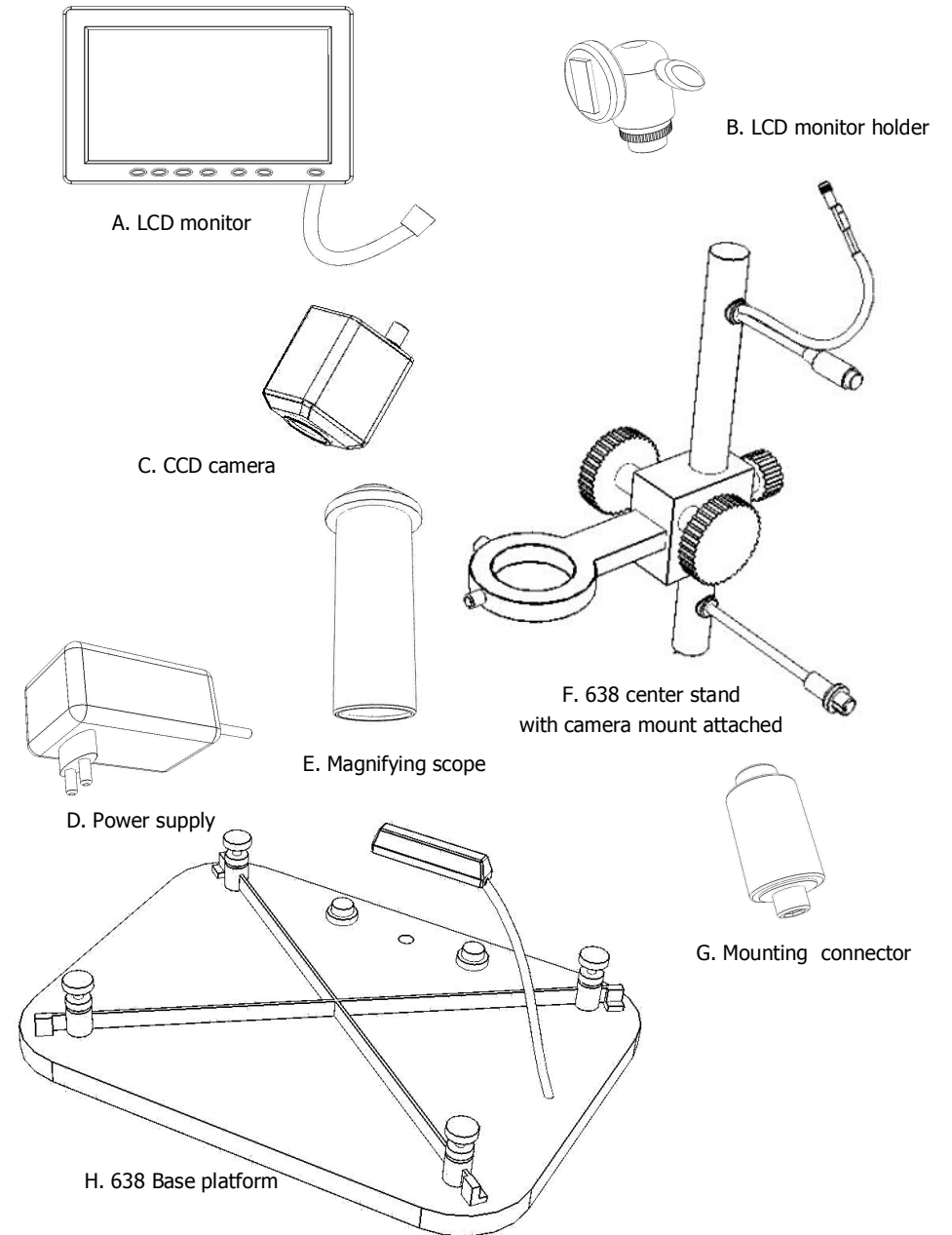

FUNCTION and FEATURES

- Color CCD camera
- Variable optical scope. Maximum of 100x magnification.
- Color LCD Display
- Versatile platform.
- Rigid mounted camera and LCD Screen.
- Adjustable camera ladder for easy focus and magnification adjustments .
- Integrated Light source.

SAFETY PRECAUTIONS

- Check each component after opening the package to make sure everything is in good condition. If there are any suspected damage, do not use the item and report the issue to your vendor.
- Unplug the device when moving the device from one location to another.
- Do not strike or subject the main unit to physical shock. Use carefully to avoid injury and damage to any part.
- Handle with care.
 - Never drop or sharply jolt the unit.
 - Contains delicate parts that may break if the unit is dropped.
- Disconnect the plug from the power source if the unit will not be used for a long period.
 - Turn off power during breaks, if possible.
- Use only genuine replacement parts.
 - Turn off power and let the unit cool before replacing parts.
- Do not alter the unit, specifically the internal circuitry, in any manner.

ASSEMBLY

1. Top mount assembly:
 - Attach LCD screen holder (B) to the top of the center stand (F). (see Fig.1)
2. Attach the Mounting connector (G) to the base platform (H). (see Fig. 2)
 - Detach the screw from the mounting connector.
 - Position the mounting connector to the hole in the base platform.
 - Lock the mounting connector securely with the screw.

